

HOCHIKI ADDRESSABLE CALL POINT INSTALLATION INSTRUCTIONS



Products covered: HCP-W, HCP-W(DPS), HCP-W(SCI) & HCP-WM

IMPORTANT: These call points are suitable for use only with the particular class of system for which they are intended. These units are only compatible with the Enhanced Systems Protocol (ESP). All units are weatherproof and can be installed externally. **Important Note – The use of lubricants, cleaning solvents or petroleum based products should be avoided.**

SETTING THE ESP LOOP ADDRESS

Ensure that each device has a unique address set before operation. Note the address can be set before or after connection to the loop but the loop **MUST NOT** be powered. The address is set by connecting a hand held programmer (TCH-B100) to the programming connector inside the unit. To access this, first remove the four cover screws located at the top and bottom of the unit (see fig 1). Place the blade of a screwdriver into each of the grooves between the black back section and red front section and twist to separate the two halves (see figs 2 and 3).

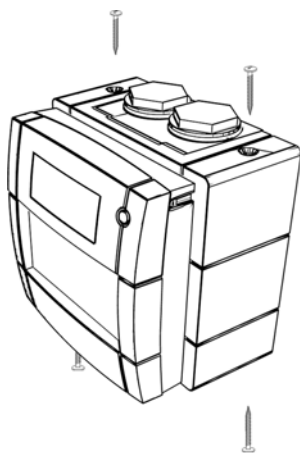

fig 1

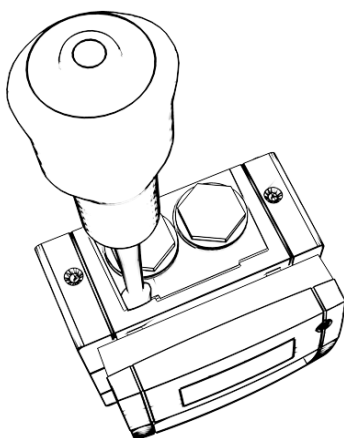

fig 2

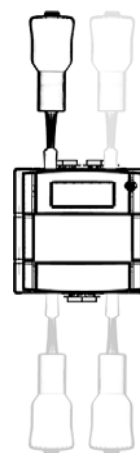

fig 3

The programming connector is located on the reverse of the front section of the call point (top left corner). Using a PL-3 programming lead, plug the square connector of the PL-3 on to the programming connector on the call point, note the connector is **NOT** polarised (see fig 5). Plug the jack plug end of the PL-3 into the TCH-B100. Set the address in the usual way (see the TCH-B100 Instructions for further details). Once the address is stored remove the programming lead.

STATUS LED

The call point incorporates an LED mounted on the front cover which is continuously lit red when the device is operated. The HCP-W(SCI) incorporates a bi-coloured LED; the LED will show amber when a short-circuit is present but will switch to red when the unit is operated.

POLLING MODE

The polling mode of the call point (whether the call point will flash intermittently when connected to the loop) is controlled via the connected control panel (check control panel compatibility). Note that factory default for all models is flashing mode.

MOUNTING / CONNECTION

The weatherproof back box section of the unit (black) should be mounted directly on the wall or final fixing position with three screws (supplied). The provided screw holes **MUST** be used; making any other holes in the back box will void the IP rating. To avoid damage to the back box do not over tighten screws. Use appropriate weatherproof cable glands (not supplied) within the glanded cable entry holes. Note, two blanking plugs are supplied (see fig 4). A metal cable earthing shield is also provided, this should be fitted around the cable entry hole before the cable gland is fitted and a suitable earth attached if required.

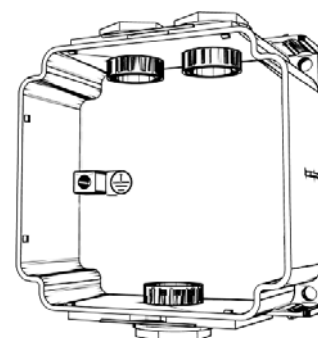

fig 4

Wire the unit to the loop cables using the terminal blocks, note these blocks can be removed for easier connection (see fig 5).

Wire the loop cables as per the wiring diagrams shown below (see figs 6 and 7). The loop connections must not be greater than 2.5mm² cable diameter for proper fixing to the terminal blocks. If required, cable screens can be terminated at the earth terminal within the back box (see fig 4).

Once connected fix the front section of the unit call point to the back box, pushing the two halves together to engage clips. At this point ensure the gasket seal is intact and in place (Note: The gasket should be replaced when refitting or replacing the Water Cover). Fix the four cover screws (see fig 1).

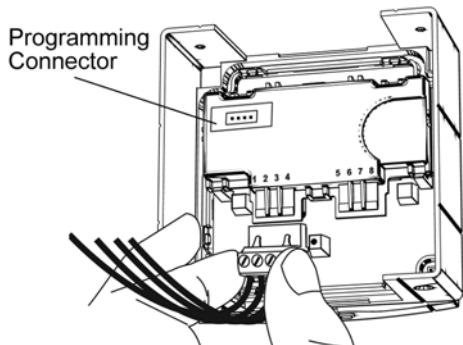

fig 5

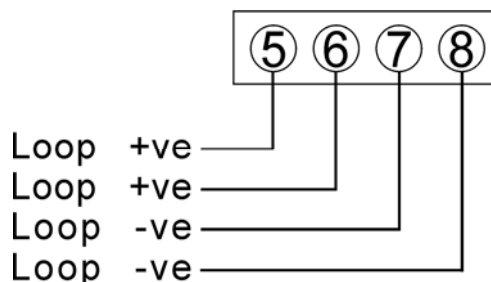

fig 6

TESTING

To test the call point insert the supplied test key into the aperture at the bottom of the unit until the lower cover opens. The non-frangible element will drop, thus simulating operation of the call point (see fig 8).

To reset the unit after testing remove the key and slide the lower cover up (with the non-frangible element) back into place until it clicks shut (see fig 9).

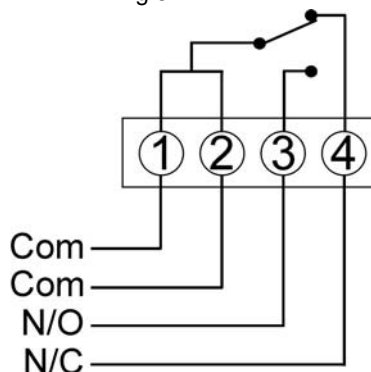

fig 7 – HCP-W(DPS) additional wiring

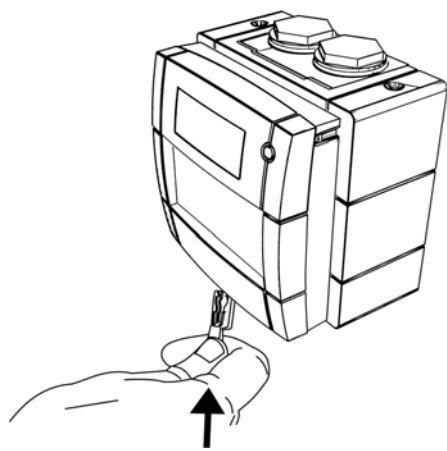

fig 8

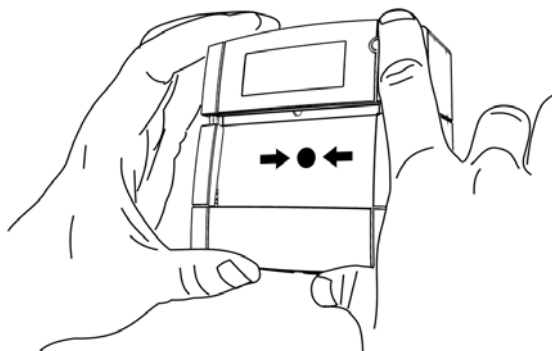

fig 9

RESETTING AFTER ACTIVATION

To reset the call point after it has been activated, insert the supplied test key into the aperture at the bottom of the unit until the lower cover opens, remove key. If a glass element has been used, remove cover, replace glass element and replace cover. Then slide the lower cover up (with the element) back into place until it clicks shut (see fig 8).

	HCP-W, HCP-WM, HCP-W(DPS)	0832-CPD-0602	07	EN54-11 Manual Call Points
	HCP-W(SCI)	0832-CPD-1239	09	EN54-11 Manual Call Points EN54-17:2005 Short-Circuit Isolators



Hochiki Europe (UK) Ltd
 Grosvenor Road, Gillingham Business Park,
 Gillingham, Kent, ME8 0SA, England Telephone:
 +44(0)1634 260133 Facsimile: +44(0)1634 260132
 Email: sales@hochikieurope.com
 Web: www.hochikieurope.com

Hochiki Europe (UK) Ltd. reserves the right to alter the specification of its products from time to time without notice. Although every effort has been made to ensure the accuracy of the information contained within this document it is not warranted or represented by Hochiki Europe (UK) Ltd. to be a complete and up-to-date description. Please check our web site for the latest version of this document.